



# VEHICLE HANDLING MANUAL

**Subaru of America, Inc.**  
**Sales / Logistics**  
**February 2021**



# **TABLE OF CONTENTS**

<b>INTRODUCTION.....</b>	<b>3</b>
<b>CHANGES TO 2021 HANDLING MANUAL .....</b>	<b>4</b>
<b>GENERAL PROCEDURES .....</b>	<b>5</b>
Personnel .....	5
Minimum Operating Standards – Facilities/Terminals .....	5
Vehicle Handling .....	6
HVAC Control Settings.....	7
Vehicle Starting Procedure.....	8
No Start Condition .....	9
Troubleshooting No Start Condition .....	10
Electronic Parking Brake .....	11
Loading and Unloading Procedures .....	12
Placement of Keys .....	14
<b>TRUCK-AWAY INSTRUCTIONS.....</b>	<b>15</b>
Car Carrier Truck Equipment .....	15
Exterior/ Interior Inspection Process.....	15
Loading Procedures .....	17
Tie-Down Procedures.....	20
Outgate Procedures .....	21
On the Road.....	22
Unloading .....	22
Damage Notification Procedure .....	22
<b>RAIL HANDLING .....</b>	<b>23</b>
Rail Car Equipment .....	23
Preparation for Loading.....	24
Loading Procedure.....	25
Tie-Down Procedures.....	28
Unloading .....	30
<b>PROCEDURE FOR HANDLING DAMAGED SUBARU VEHICLES AT RAIL DESTINATIONS .....</b>	<b>32</b>
<b>APPENDIX A: SUBARU OF AMERICA KEY STYLES BY MODEL .....</b>	<b>33</b>
<b>APPENDIX B: 2021 VEHICLE WEIGHTS/DIMENSIONS .....</b>	<b>34</b>
<b>APPENDIX C: DELIVERY INSPECTION EXPECTATIONS .....</b>	<b>37</b>
<b>APPENDIX D: CROSSTREK HYBRID HANDLING AND SERVICE.....</b>	<b>37</b>



## **INTRODUCTION**

Published by the Subaru of America (SOA) Logistics Department in cooperation with Subaru Yard Operations, SOA Port Facilities, Quality Control, Risk Management and Service Departments, this manual is provided to assist in accomplishing the goal of damage free delivery to the customer.

All procedures and requirements detailed in this manual for the handling, loading, transport, unloading and storage of Subaru vehicles must be adhered to, unless previously agreed upon in writing by SOA.

This manual contains information in regard to General Procedures, Truck-Away Instructions, Rail Handling Instructions, Damage Notification Procedures and Current Model Vehicle Weights and Dimensions.

In addition to the instructions provided, transport personnel are to follow the procedures specified by their company at all times to prevent vehicle damage and ensure safety during loading, unloading and transport operations. Any conflict in those procedures and the instructions in this manual are to be brought to the attention of the Subaru Logistics Department for resolution.

All personnel involved with the handling of Subaru vehicles are to be fully aware of the procedures detailed in this manual.

Any suggestions or questions concerning the material presented, or requests for additional copies should be directed to:

Subaru of America, Inc.  
Logistics Department  
P.O. Box 6000  
Crimson Hill, NJ 08034-6000  
FAX (856) 488-3138

856-488-3428  
[mole@subaru.com](mailto:mole@subaru.com)



## **Changes to 2021 Handling Manual**

Below are the highlights of the changes and updates that have been made in the 2021 Vehicle Handling Manual.

- This manual contains information regarding General Procedures, Truck-Away Instructions, Rail Handling Instructions, Damage Notification Procedures and Current Model Vehicle Weights and Dimensions.
- In addition to the instructions provided, transport personnel are always to follow the procedures specified by their company to prevent vehicle damage and ensure safety during loading, unloading and transport operations. Any conflict in those procedures and the instructions in this manual are to be brought to the attention of the Subaru Logistics Department for resolution.
- Appendix B - 2021 Model Year weights and measures updated
- Appendix C – Delivery Inspection Expectations - added
- Appendix D - Hybrid Vehicle information for Hybrid Crosstrek – updated

All personnel involved with the handling of Subaru vehicles are to be fully aware of the procedures detailed in this manual.

Any suggestions or questions concerning the material presented, or requests for additional copies should be directed to:

Subaru of America, Inc.  
Logistics Department  
One Subaru Drive  
Camden, NJ 08103-9800 FAX (856) 488-3138

856-488-3428  
[mole@subaru.com](mailto:mole@subaru.com)



# **GENERAL PROCEDURES**

## ■ **Personnel**

- Wear clean gloves at all times.
- Clothing should be clean without any exposed buttons, zippers, belt buckles, etc. Avoid wearing rings, watches and bracelets. If worn, these must be covered.
- Protective interior vehicle coverings are to be kept in place.
- Keep tools from contacting vehicles. Do not carry tools in clothing pockets.
- Use protective covering on tie-down tool handles.
- Keep all objects off vehicle surfaces.
- No smoking, eating, drinking or lounging inside the vehicles.
- Intoxication of any kind will not be tolerated. Violators will be prosecuted.
- Hand-held device use is prohibited while driving vehicles, including cell phones.
- Seat belts are to be worn any time the vehicle engine is running.

## ■ **Minimum Operating Standards – Facilities/Terminals**

Any area where Subaru vehicles are to be stored, processed, loaded or unloaded is to be completely paved and fenced with adequate lighting and proper security provided. Loading and staging areas must be clearly marked. These areas must be level and possess an adequate drainage system.

Operational fire extinguishers must be strategically located and highly visible. All personnel should be trained to know where extinguishers are located and how to use them.

Entire area must be free of trash, debris, pot holes and loose gravel. Vegetation must be controlled throughout the facility to prevent contact with vehicles and to allow an unobstructed view of the interior perimeter of the fence.

Vehicle parking bays must be clearly marked and wide enough to permit opening doors without damage to nearby vehicles. To ensure that maximum side-to-side spacing is maintained, vehicles must be parked with the left tires on the left line of the parking bays. There is to be a minimum 10" clearance between any portion of the vehicle and the nearest point of contact.

Non-authorized vehicles are prohibited from the loading and staging areas. Subaru vehicles are not to be used for shuttle purposes. All vehicles leaving the facility will be subject to inspection.

A battery-charging program must be implemented.

## ■ Vehicle Handling

- Enter and exit through the driver's door only.
- Before driving vehicles, all doors must be shut.
- Protective seat and floor covers are to remain in place at all times.
- All windows, hoods, trunk lids, tailgates, moon-roofs and doors should be closed and secured.
- Always activate the vehicle's washer unit prior to engaging the wiper system.
- For any Subaru models with folding exterior mirrors, the mirrors must be in the folded position. Some models have power folding mirrors which are controlled by a switch on the driver's door. Manually folding power mirrors can cause damage.



Power folding exterior mirror switch



- Some Subaru models are equipped with two forward facing cameras mounted in the overhead console (see below). These lenses must not be touched or wiped for any reason.

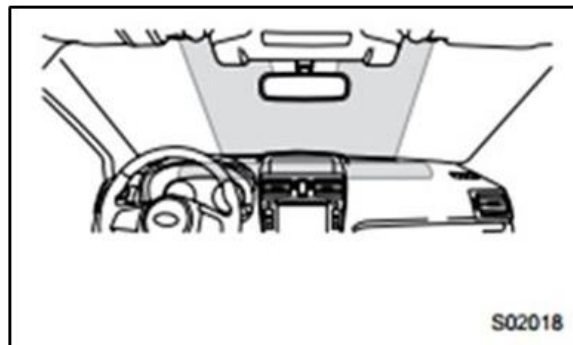
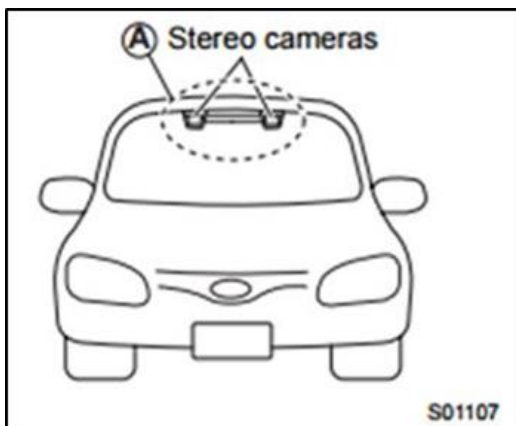

- Flat tires must be changed before a vehicle is moved. Under no circumstances are vehicle tires to be deflated to reduce vehicle height.
- Vehicles must be loaded and unloaded under their own power.
- *Never* push or pull a vehicle with another vehicle. Dead batteries are to be recharged or replaced. No vehicle is to be delivered to a retailer with a dead battery. See below for handling No Start issues.

▼ **HVAC Settings –**

- Heating, air conditioning and all electrical controls should be in the “OFF” position with vents closed. Infotainment system is to remain “OFF” at all times.
- **\*NOTE –** on some models, HVAC controls are integrated into the center information display touch screen.
  - With the vehicle in transit mode the HVAC controls cannot be adjusted. The vehicle will retain the last setting of the HVAC before the backup fuse is removed.



▼ **Recommended Transit Mode Settings –** The work around for the inoperative transit mode HVAC is to place the unit in a set mode where maximum defogging/defrost can occur before removing the back-up fuse.

- **Recommended transit mode setting.**
  1. Set temperature control to 70.
  2. Turn on front defrost.
  3. Set fan speed to high.





## ■ Vehicle Starting Procedure

- 1 Apply the brake.
- 2 **Manual Transmission:** Press the clutch pedal to the floor and move the shift lever into neutral. Hold the clutch pedal to the floor while starting the engine. The starter motor will only operate when the clutch pedal is pressed fully to the floor.
- 3 **Automatic Transmission:** Shift the selector lever to the “P” or “N” position (preferably “P” position). The starter will only operate with the select lever is at the “P” or “N” position.
  - a **Vehicles with Turn Key Start**
    - i Turn the ignition switch to the “ON” position. Several of the warning and indicator lights will come on momentarily.
    - ii Turn the ignition switch to the “START” position **without** applying the accelerator pedal. Release the key immediately after the engine has started.
  - b **Vehicles with Push-Button Start:**
    - i It is imperative that the brake is **FULLY** applied when starting these vehicles.
    - ii Simply apply the brake and push the Engine Start button once. If the brake is not depressed and the start button is not cycled to “OFF,” the battery will die on the vehicle.
    - iii Push-Button Start vehicles also contain “FOB” remotes (see access key image below) that must be placed inside of the vehicles in order for them to start.
- 4 **Do not operate the starter motor continuously for more than 10 seconds.**

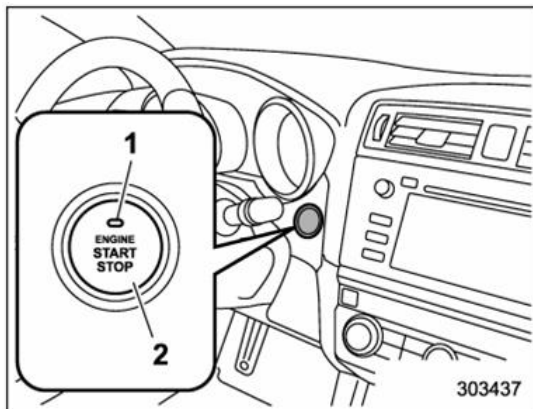

- 1) Operation indicator
- 2) Push-button ignition switch

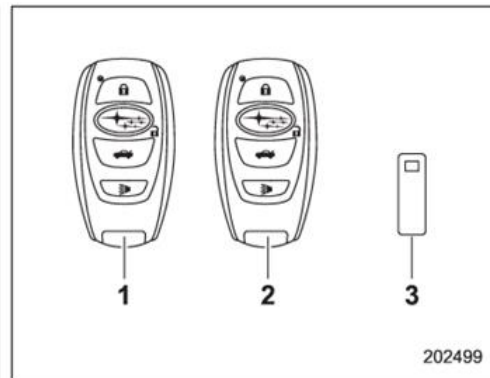

- 1) Access key (main)
- 2) Access key (sub)
- 3) Key number plate



■ **No Start Condition** - If the engine does not start, try the following:

▼ **Engine “No Start” Condition – Turn Key Start**

1. Turn the ignition switch to the “Lock” position and wait for at least 10 seconds. Ensure that the parking brake is firmly set. Next, turn the ignition switch to the “Start” position while applying the accelerator pedal slightly (approximately  $\frac{1}{4}$  of the way down). Release the accelerator pedal as soon as the engine starts.
2. If this fails to start the engine, turn the ignition switch back to the “Lock” position and wait at least 10 seconds. Ensure that the parking brake is firmly set. Then, fully apply the accelerator pedal and turn the ignition switch to the “Start” position. If the engine starts, quickly release the accelerator pedal.
3. If this fails to start the engine, turn the ignition switch to the “Lock” position. After waiting at least 10 seconds, turn the ignition switch to the “Start” position without depressing applying the accelerator pedal.
4. If the engine still will not start, turn the ignition switch back to the “Lock” position and contact the yard office.
5. If the techniques above do not work, the vehicle may have to be jump started.

▼ **Engine “No Start” Condition – Push-Button Start**

1. Apply the parking brake.
2. Shift the select lever into the “P” position (or neutral in manual transmission).
3. Depress the brake (and clutch if manual transmission).
4. Hold the access key with the buttons facing you and touch the push-button ignition switch with it (see below). When the communication between the access key and the vehicle is completed, a chime (ding) will sound. At the same time, the status of the push-button ignition switch changes to either of the following:
  - When the keyless access with push-button start system is deactivated: “ACC”
  - Under other condition: “ON”
5. When the keyless access with push-button start system is deactivated, press the push-button ignition switch with the brake pedal released. The status of the push-button ignition switch then changes to “ON”.

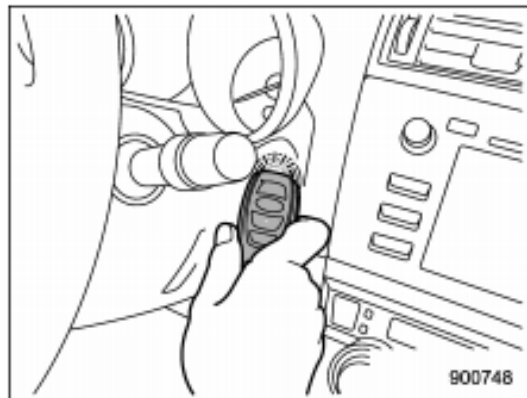

**If the techniques above do not work, the vehicle may need to be jump started.**

■ **Troubleshooting No Start Condition** – Additional steps to follow if engine does not start:

▼ **Steering Wheel Lock – Push-Button Start** - The following precautions should be considered with the steering lock:

▽ **Operation Indicator Flashing in Green**

1. Check the select lever is set in the “P” position.
2. Depress the brake pedal and keep it.
3. Press the push-button ignition switch while turning the steering wheel left and right

▽ **Operation Indicator Flashing in Orange**

1. There may be a malfunction in the steering lock function. Contact the yard office.

▼ **Jump Start Procedure** - If vehicle cannot be started, jump starting may be required.  
**\*NOTE\*** - See [Appendix D](#) for specific Crosstrek Hybrid Jump Starting Steps

1. Connect one jumper cable to the positive (+) terminal on the discharged 12V auxiliary battery.
2. Connect the other end of the jumper cable to the positive (+) terminal of the booster battery.
3. Connect one end of the other cable to the negative (-) terminal of the booster battery.
4. Connect the other end of the cable to the strut mounting nut of the vehicle with the discharged 12V auxiliary battery.

**CAUTION:** Make sure that the cables are not near any moving parts and that the cable clamps are not in contact with any metal.

5. Start the engine of the vehicle with the booster battery and run it at a moderate speed.
6. When finished, carefully disconnect the cables in exactly the reverse order.

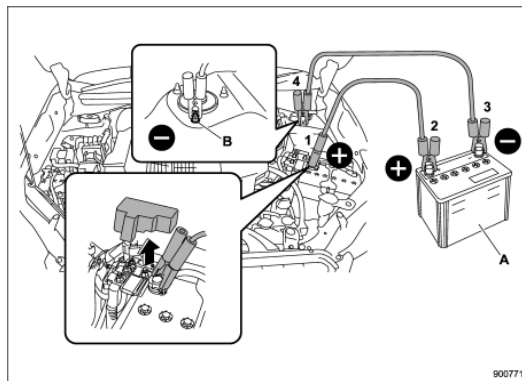

A) Booster battery  
B) Strut mounting nut

Caution must be taken when jump starting a vehicle to ensure cable clamps do not come in contact with any vehicle surface. Contact can scratch painted surfaces and create dangerous electrical conditions.

If the jump start procedure does not work, contact Vehicle Claims for further instruction.

If vehicle is on a rail car and jump start procedure does not work, it may be pushed off the rail car to continue unloading process. Never push the disabled vehicle with another vehicle.

**Do not jump start a vehicle if the engine cranks when attempting to start it.**

## ■ Electronic Parking Brake

The Ascent, Forester 2019, Legacy, Outback and WRX (CVT) models are equipped with an electronic parking brake system. Before driving the vehicle, make sure the parking brake has been released and the brake system warning light is turned off.

**To release:** Start the vehicle, apply the brake pedal (and the clutch pedal on MT models) and push the parking brake switch down.

**Note:** There is an automatic release of the parking brake when all doors are closed, the driver's seatbelt is fastened, and the accelerator is depressed.

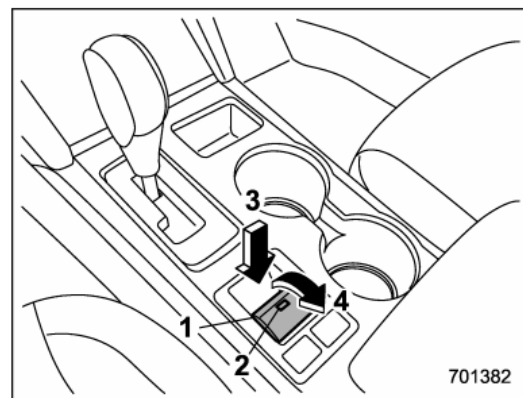

- 1) Parking brake switch
- 2) Indicator light
- 3) Release the electronic parking brake
- 4) Apply the electronic parking brake

## ■ Loading and Unloading Procedures

- When unlash vehicles from import vessels, lashes are to be removed and pushed along the floor to the edge of the deck. Please take extreme caution to ensure that the lashes do not fall under the railing, damaging the vehicles beneath or picked up from the floor until the vehicle is moved.
- Verify the Vehicle Identification Number (VIN) on all documents and vehicles.
- Never push or pull a vehicle with another vehicle.
- Observe all warning lights and follow instructions in the owner's manual.
  - The “check engine” light flashing while engine running is normal in all Subaru models. This indicates that vehicle is in “transport mode”.
- Do not allow engines to idle for extended periods of time.
- Drive with the flashers and headlights on at all times.



A **maximum** speed of **15 MPH** in the facility or terminal and **5 MPH** at ramps is to be observed at all times. A minimum of one vehicle length is to be maintained between moving vehicles.

To move a Manual Transmission vehicle in reverse, the “slider” (1) must be lifted and held in the raised position before the shift lever can be moved to the “R” position. The vehicle **MUST** only be placed into reverse when it is completely stopped. To change gears, fully depress the clutch pedal, move the shift lever, and gradually let up on the clutch. If it is difficult to shift into gear, put the transmission in neutral, release the clutch pedal momentarily, and then try again.

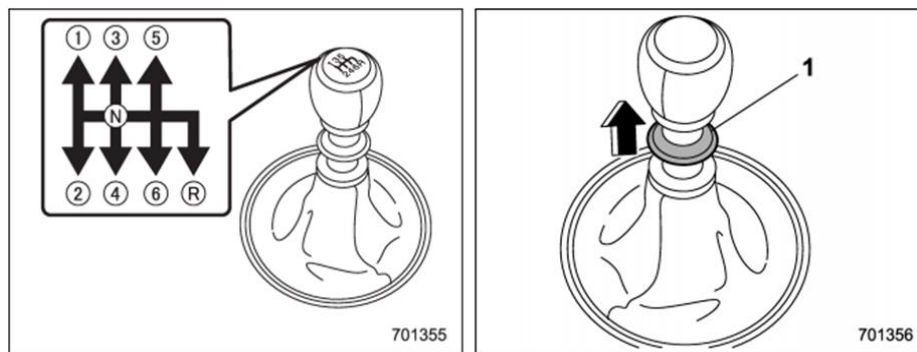

If a driver must move an unassigned vehicle to get to the assigned vehicle for loading, the unassigned vehicle must be returned to its original position.

Exercise extreme caution during loading and unloading operations to prevent any part of the vehicle from touching any part of the transport vehicle.

Vehicles must be properly positioned on the transport vehicle runways to prevent sidewall chafing of the tires and to permit positive engagement of the securement devices.

After the vehicle is loaded or parked, transmission select lever must be set as follows:

- **Loaded on Rail**: “Park” (automatic) or first gear (Manual), parking brake set
- **Loaded on Truck**: “Park” (automatic) or first gear (Manual), parking brake set.
- **Parking Lot**: “Park” (automatic) or first gear (Manual), parking brake set.

## ■ Placement of Keys

- **See Appendix A, for pictures of keys for all CURRENT Subaru models**
- Keys are to be placed in center console with lid left down. See below picture for key placement.
- Doors are to remain unlocked.
- Never leave keys in the door or ignition.



When exiting the vehicle, ensure that the ignition system is “OFF” (the key turned counter clockwise to the furthest point of rest) before removing the key.

The keys must ALWAYS be removed to ensure the cars are truly off.

Verify that instrument cluster lights, accessories and infotainment system are off.

To shut the engine off on Keyless Push-Button Start vehicles, place vehicle in park and push the button once.



# **TRUCK-AWAY INSTRUCTIONS**



Please note: At Lafayette when entering the facility, drivers must obtain a Motor Pool Gate Pass from the security office or their on-site dispatcher.

## **■ Car Carrier Truck Equipment**

All truck-away equipment must allow various Subaru vehicles to be carried in a safe and secure manner.

Equipment must be designed to allow entry and exit of the vehicles without contacting any metal surfaces of the car carrier truck.

Vehicles must not be loaded in any position that would require the driver to enter or exit by any means other than the front driver's side door.

Trucks must be equipped with soft tie-downs (straps).

Vehicles in "lower" positions must be protected against damage from fluid leakage or hot exhaust from a vehicle loaded in an "upper" position.

The maximum permitted distance to "jump" a vehicle between deck sections is 4". For any distance greater than 4" jumper plates or skids must be used.

All truck away equipment must be in excellent working condition. Periodic inspections must be performed to determine if repair or replacement is required.

## **■ Exterior/Interior Inspection Process**

- Do not remove plastic wrap during initial inspection unless there is an indication of damage - plastic wrap is torn, dirty or scratched. The condition of the plastic wrap must be described on the delivery receipt. If damage is found under "undisturbed" plastic wrap, the repair is NOT recoverable as transportation damage. Such damage must be inspected by your District Parts and Service Manager for coverage determination. (See New Vehicle Care in Section 3.2.)



- Check all body panels, trim and paint finish for scratches, dents or fluid damage.
- Check the bodyline of the vehicle, paying careful attention to the fit of the hood with the fenders and the front bumper. Also, notice the clearance between the taillights and the rear bumper. Wider than normal clearances and/or too close tolerances between body panels should be noted on the delivery receipt with a statement of possible hidden damage (undercarriage).
- Check all glass for cracks, scratches or chips.
- Check all tires, including the spare, for cuts or punctures.
- Check under the hood for any missing equipment or evidence of leaking fluids.
- Inspect all trim panels, upholstery, carpets, dash, sun visors, headliner and door trim.
- Check for tool kit, jack, wheel covers, keys and Owner Information Kit (OIK) and, if applicable, the Navigation SD Card (stored in a red static-free bag in under-floor storage compartment – See Appendix C).

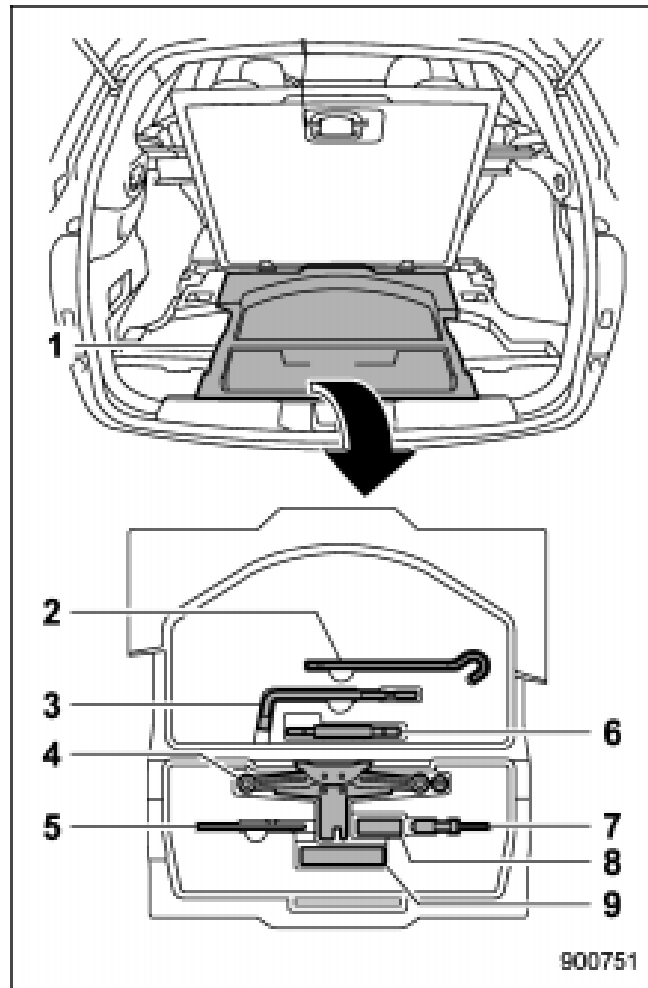

## ■ Loading Procedures

### ▼ Prior to Loading

- Inspect the truck to ensure that the vehicle pathway is clear of loose securement devices hanging from upper decks
- Jump skids or plates are properly positioned
- Deck sections are positioned to avoid vehicle contact during loading
- Verify that the Monroney label applied to the vehicle matches the actual VIN plate
  - Monroney labels are applied to the left rear window except for the BRZ, which will have labels applied to the right front window
- Verify that all accessories and equipment listed on the Monroney label are present in/on vehicle
- Verify that the shipping destination matches the load sheet information

Vehicles must never be transported in a manner that allows the vehicle to exceed 15 degrees from horizontal. During loading, unloading, and all other handling situations other than transporting, never position a vehicle to exceed 25 degrees from horizontal.

A minimum of 2" clearance must be maintained between all vehicle components and the car carrier trailer.

Special caution should be taken when entering and exiting vehicles to ensure that the door does not touch any part of the carrier.



At all times, avoid contact with the vehicle from securement devices.

The Subaru BRZ and Impreza models are extremely low to the ground and thus are susceptible to under bumper damages during the transport process. We are aware that there are 2 styles of trailers/ramps utilized on car carrier trucks. One ramp has a more gradual incline (picture 1, example A), while the other has a more drastic “drop” to the ground (picture 1, example B). Picture 1 example B style ramp configuration causes the front end of vehicles to come extremely close to the ground (picture 3), especially the BRZ and Impreza models. If using Example B style of ramp, ramp pads or steel plates MUST be used to avoid having the front bumper hit the ramp (see picture 2).

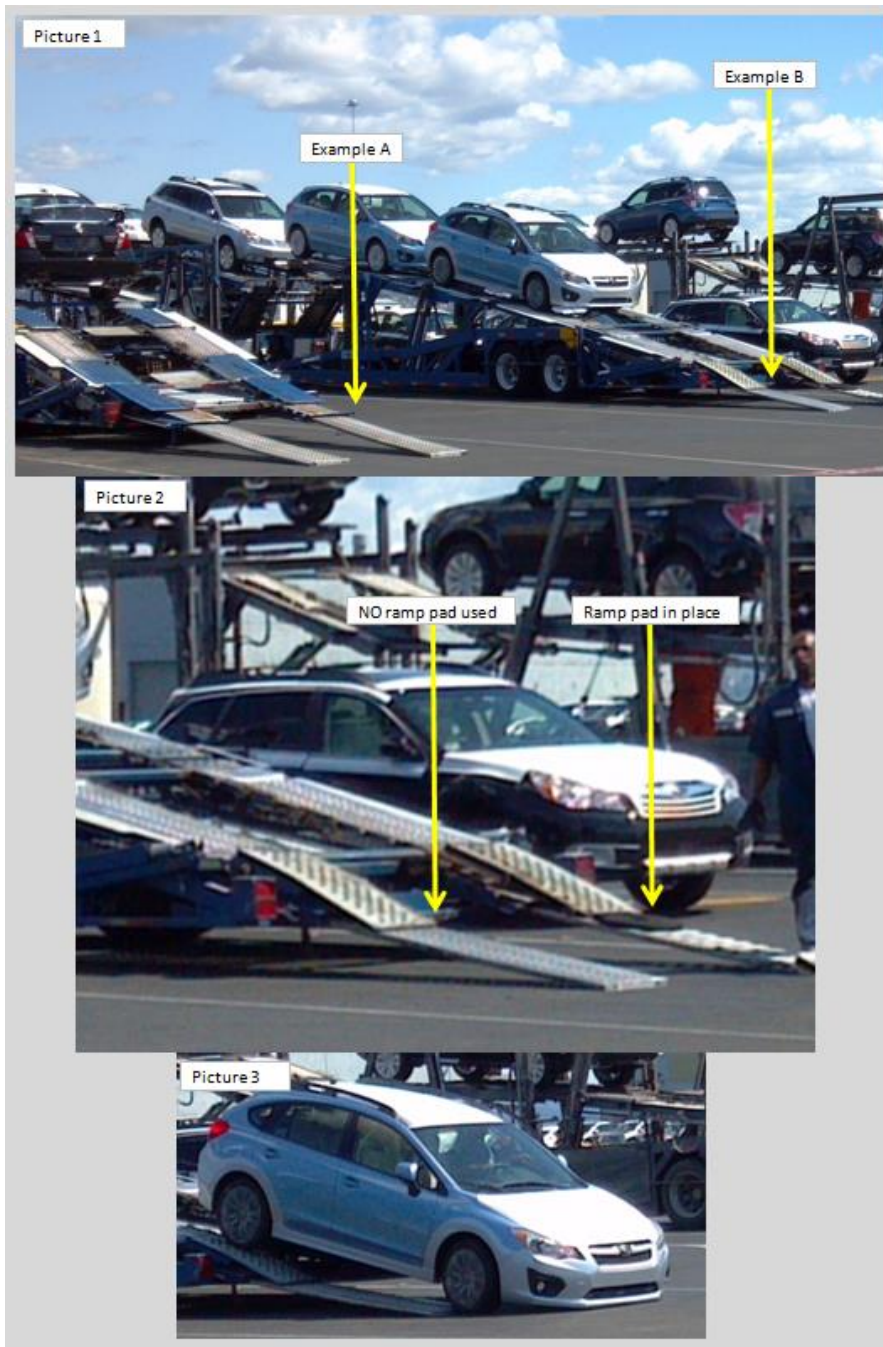

Particular caution is to be taken with the loading of each specific model listed:

### ▼ WRX/STI/BRZ Models

Ensure loading ramps are fully extended for proper clearance of both front and rear bumper “ground effects”. Please take extreme caution.

### ▼ BRZ Model

The rear bumper (which is under the exhaust tailpipes and runs the length of the rear bumper) of this model decreases the rear height clearance. Extreme caution must be taken when loading the BRZ. Also, note that when checking for floor mats, which are located in the trunk of the BRZ, drivers may come across a locked trunk. The trunk release switch is on the dash located to the left of the steering wheel. The release must be pressed and held for a few seconds, as a quick press will not release the trunk. If the trunk does not open from the switch on the dash, the keys must be used to open the trunk (likely because the trunk release cancel option has been activated). The lock cylinder is found on the bottom right side of the trunk lift handle. For BRZs with the auto start, the key is found within the keyless entry remote itself. A button on the back of the keyless start remote must be pushed to release the key from within the device (see images below for reference).

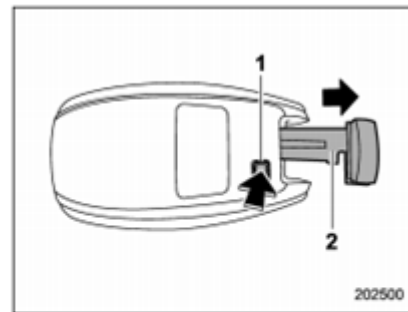
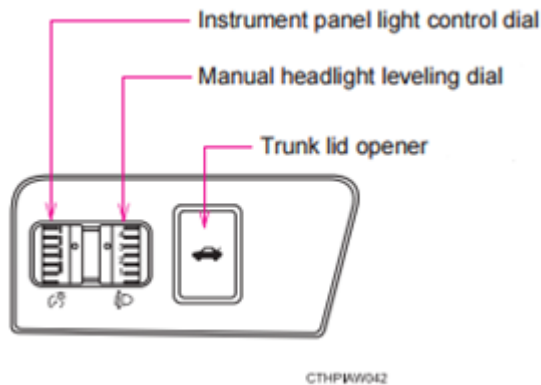

- 1) Release button
- 2) Mechanical key

While pressing the release button of the access key, take out the mechanical key.

## ■ Truck Tie-Down Procedures

### ▼ Tie Down Straps – ALL 4 Tires must be secured

When using the soft tie-down, steps 1 and 6 are critical for proper tensioning of the system. Both connection points must be as far under the tire as possible in order to achieve the “wrap-around” effect that locks the tire in place.

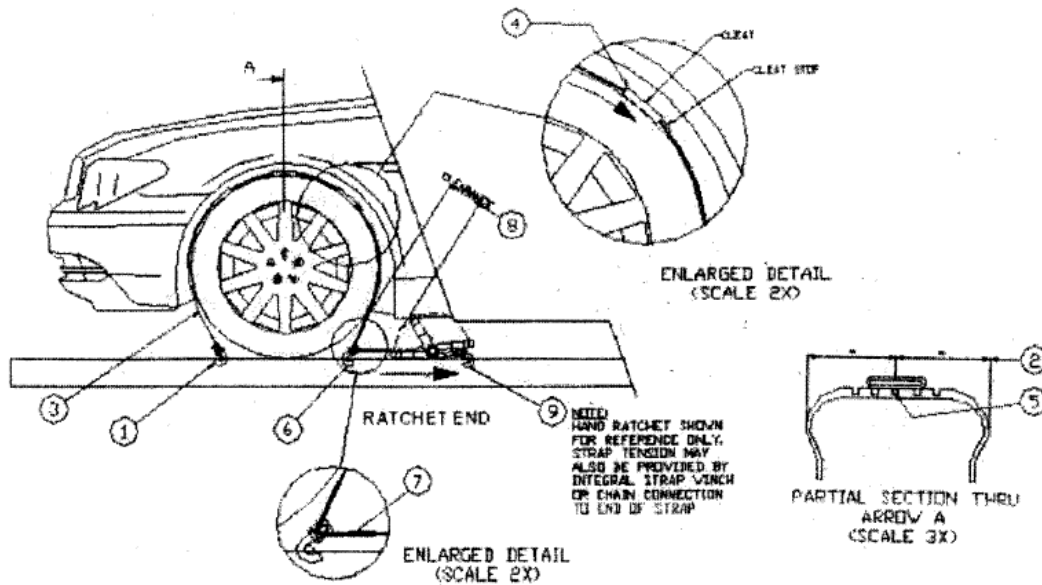

1. Lock-in the first connection point (1) as far under the front of the tire as possible.
2. Place strap over tire, ensuring that the three rubber cleats are centered across the width of the tire.
3. Ensure that any slack between the first connection point (1) and the cleats has been removed.
4. Check that the cleats are pushed as far towards the ratchet end as the cleat stops will allow.
5. Position the cleats to ensure that the dimples are securely inserted into the tire tread.
6. Lock-in the second connection (6) as far under the back of the tire as possible.
7. Make sure that the protective sleeve is evenly spaced through the roller idler.
8. When locking in the third connection point (9), allow enough room for the tensioning and full release of the ratchet. (Ratchet does not need to be in line with connection points 1 and 6.)
9. Hand tension the strap before cranking the ratchet.

▼ **Please observe the following once vehicles are tied down and secured to the Car Carrier Truck**

The following minimum clearances must be maintained:

- 2" between vehicle undercarriage and the trailer
- 3" bumper to bumper or trailer
- 4" between the roof, hood or deck lid and the top deck

When adjusting decks after loading, be aware of vehicle locations to avoid vehicle contact with upper decks.

Proper tools must be used when connecting/disconnecting tie-downs from vehicles. Tools should have a protective covering on the handles.

Inspect all vehicles for proper tie-down after loading, prior to transporting.

Stow and secure skids so they will not touch vehicles.

**Ensure the truck is under the maximum allowed height prior to departure.**

- The driver should check the load height to ensure that the loaded vehicles will not be exposed to damage from overhead obstruction while in transit.
- Vehicle tires are never to be deflated to reduce trailer heights.

■ **Outgate Procedures**

As each vehicle is loaded, the driver will place the adhesive backed barcode (found in the vehicle's center console) for each unit in the appropriate box found on the Bill of Lading or out-gate document. If a bar code cannot be found, the driver must record the vehicle's VIN in the appropriate box (the VIN is found on the vehicle's dashboard). If adhesive backed barcodes are not used at a particular port (i.e. Richmond and Vancouver) the carrier will simply collect the port processor generated release document from each vehicle.

Then, outgate documents are scanned by the Port Processor. Upon exiting all facilities, the driver must present the Bill of Lading/Outgate document with barcodes (or handwritten VINs) to the Security Officer. The Security Officer will confirm that the number of barcodes match the number of vehicles loaded. Drivers will not be permitted to exit a Subaru processing facility without the completed documents.



## ■ On the Road

During transport, all tie-downs are to be inspected periodically, making any necessary adjustments.

On-time delivery is of prime concern to SOA. Drivers need to promptly report transportation delays to the dispatcher. Such reports should include the location, cause and expected length of the delay.

## ■ Unloading

Vehicles shall not be positioned to exceed 25 degrees from horizontal.

A minimum of 2" clearance must be maintained between all vehicle components and the trailer.

Tie-down contact with any part of the vehicle must be avoided at all times.

## ■ Damage Notification Procedure

SOA uses the industry inspection standard set documented in the AIAG damage coding system. All transportation damage notation should use this standard.

If a vehicle sustains major damage during transportation, the Transport Carrier is to notify SOA immediately (within one business day of the incident) by calling the Logistics Department at **856.488.8681** or emailing **vehicle\_claims@subaru.com**. The Transport Carrier will then hold the vehicle and await instructions from SOA Logistics regarding the disposition of the vehicle.

Under Subaru policy;

- Retailers are instructed to accept a damaged vehicle
- The retailer is to note the damage on the delivery receipt
  - The retailer is to mark the delivery receipt “accept for storage only”
- However, in the event a retailer refuses delivery of a vehicle for any reason, immediately contact the SOA Logistics Department.
  - **The driver should not leave the retailer without first obtaining new delivery instructions for the vehicle.**

All delivery receipts should be signed and dated by **both** the driver and retailer personnel.

After hours and weekend deliveries (STI) are not permitted without prior written authorization from the retailer.





# **RAIL HANDLING**

## ■ Rail Car Equipment

The only securement that may be used for Subaru vehicles, without prior approval, is the Thrall Wedge Chock or the Holden Grate Lock Chock.

Chains are never to be used without prior approval obtained from the SOA Logistics Department.

Railcars must be maintained in a manner that provides damage free transportation. Railroads servicing SOA origin locations are responsible for prepping railcars, including the inspection, maintenance, and replacement of defective and/or missing equipment before rail cars are placed for loading as follows:

- Chocks (and tie-down devices if approved) are to be inspected and lubricated. Defective devices are to be repaired or replaced.
- Hinged decks are to be inspected for proper operation. Hinges are to be lubricated and the decks locked in the raised position.
- Accumulated snow, ice or debris is to be removed from all decks of the rail cars and loading ramp.
- End doors are to be inspected for proper operation and repaired as required. Under no circumstances are rail cars with missing or inoperative end doors to be spotted for loading.
- All side shielding must be in place and secured.
- The interior of rail cars must be clean and free from rust particles and flaking paint.
- If the cleaning and preparation of rail cars is performed at the loading site, all debris must be removed from the adjacent driveways, apron, and ramp area.
- Painting of railcars is prohibited in parking areas.

**If railcar problems are found, the railcar will not be loaded and the rail carrier will be contacted immediately.**

Rail carriers have the responsibility to provide and maintain portable bridge plates of sufficient length and quantity to allow safe loading and unloading.

Under no circumstances is salt to be used to melt snow or ice, to ease movement of securement devices or to gain traction on rail car decks or loading ramps.

## ■ Preparation for Loading

When spotting multi-level equipment for loading, rail cars with a difference in height of 3” or more are not to be coupled together.

Bridge plates are to be placed in the direction of travel, except when a small height variance (less than 3”) exists between multi-levels. In these cases, the bridge plates are to be attached to the high side.

When placed for loading or unloading, rail car couplers must not be compressed or extended beyond measurements listed below. Compressed couplers cause bridge plates to be improperly seated, reducing the loading height clearances.

<u>Bridge Plate Measurement</u>	<u>Distance Between Multilevel Cars</u>
53”	38 to 46”
56”	41 to 49”
Adjustable Bridge Plates	38 to 56”

Measurement is taken from the back of a bridge plate hinge support (barrel ring) of one rail car to the deck of the adjacent multi-level. For practical purposes, this measurement is from the back of the hinge support to the approximate center of the innermost lower locking pin hole of Radial type end-enclosures and to the bottom door track of Panel type end-enclosures.

**Failure to leave couplers in their normal extended position will expose vehicles to roof and undercarriage damage, as well as the risk of coupler “push-out”.**

Hand brakes are to be set on all rail cars spotted for loading. If more than 2 strokes of the brake handle can be obtained with application of moderate pressure, the brake is not fully set.

**Failure to set brakes properly will expose vehicles to major damage and may cause injury to loading/unloading personnel, should the rail car movement cause the bridge plates to fall.**

The ramp and portable bridge plates are to be positioned such that no part of the vehicle, except the tires, will contact the ground, ramp or rail car structure.

## ■ Loading Procedure

Extreme care is to be taken to prevent damage from contact with the overhead structures, coupler housings and the sides of rail cars. A minimum of one vehicle length is to be maintained between moving vehicles at all times. Speeds must be kept at 5 MPH or less when driving on loading/unloading ramps or through rail cars. Speed must be reduced when passing from one rail car to another.

Vehicles are to be positioned with regards to the securement device. This usually requires the tire to be placed approximately 2” from the chock track or centered over the tie-down channel.

Model	Bi-Level	Tri-Level	Bi-Level Articulated	Automax
Ascent	X			
Outback	X			
Impreza	X (optional, no bookends)	X	X (optional, no bookends)	B or C deck only
Forester	X			
WRX	##	X		
WRX/STI	##	X		
BRZ		B or C deck only		
Crosstrek	X			
Legacy	X (optional, no bookends)	X	X (optional, no bookends)	B or C deck only

- ## - WRX, WRX/STI and BRZ only loaded on Bi-level rail cars with SOA consent.
- Ascent, Crosstrek, Forester and Outback models are to be loaded on Bi-level rail cars only.
- The BRZ model can be placed on a B or C deck only.

### BRZ Specific Notes:

For the BRZ model please be aware that there is only about 3 ½" of clearance under the front spoiler when moving the vehicle from the pavement to the first transition. From testing the loading process, Subaru has seen that there is sufficient under car clearance from the ramp to the railcar and also between railcars. Also, testing has shown that there is decent clearance when chocking the front wheels. Be aware that when chocking the rear wheels, caution should be used to ensure that the chock is not touching the air flaps. See pictures below for reference.

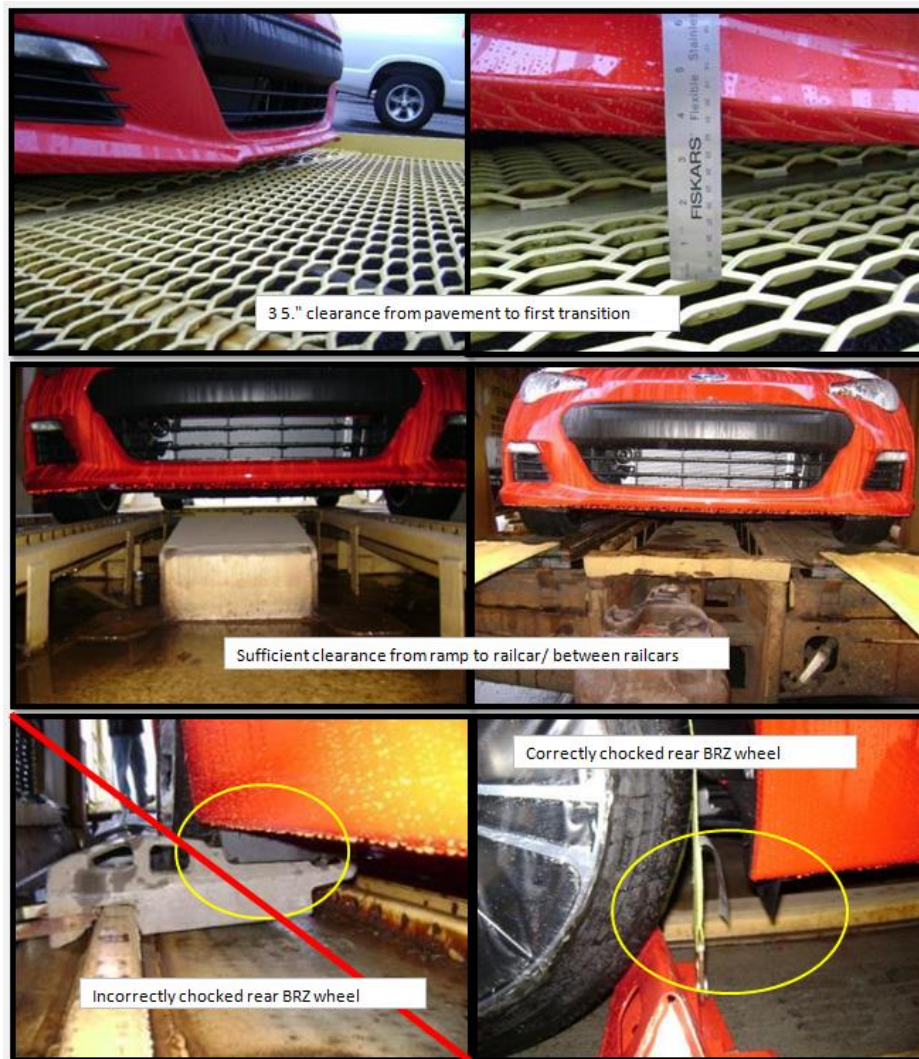

Only the BRZ, Legacy, Impreza, WRX and STI models can be loaded on a Tri-level rail car.

For Legacy models only load four units on A deck leaving position A5 empty. To prevent left front door paint chips on vehicles, it is necessary to place your hand at the top of the "full framed door window" when entering and exiting the vehicle.

Vehicles are to be uniformly positioned on each deck to maximize the distance between vehicles and end-enclosures. Vehicles must not extend beyond the rail car's striker plate. At the closest point, vehicles must be at least 3" apart.

When loading rail cars with hinged "B" decks, vehicles loaded on the "A" deck must be properly secured before lowering and locking the hinged deck. Extreme care should be used to ensure that no part of the hinged deck rests on any part of the roof of the vehicles loaded on "A" deck.

The description for the location of vehicles on multi-level cars is shown below. The number one position is the first vehicle to be driven onto the deck and then follow in sequence.

#### Bi-Level Rail Car



#### Tri-Level Rail Car



Vehicles must not be spotted with tires resting on opening between deck plates.

**All vehicles must be in "PARK" with the emergency brake applied.**

Inspect each vehicle on the multi-level to ensure that proper loading and securement procedures have been followed.



## ■ Rail Tie-Down Procedures

### ▼ Thrall Wedge Chock

Vehicles to be chocked are to be positioned so that the sides of the tires are no closer than  $\frac{1}{2}$ " from the chock tie-down track. The ideal vehicle position allows the chock harness or strap to extend vertically from the attachment point on the chock over the centerline of the tire. This usually requires the tire to be placed approximately 2" from the track.



There is to be at least 3" of clearance above all vehicles. This is very critical at the A-1 and A-5 positions.

Vehicles are to be uniformly spaced on each deck and must be no less than 3" apart at their closest point of contact.

### ▽ Installation Procedures

- Remove one set of chocks from the storage area.
- Be careful to make no contact with the vehicle.
- Place chocks on tie-down track with one chock on each side of the tire, then slide chocks up tight to tire.
- Lock chock in place, if the chock is more than  $1\frac{1}{4}$ " away from the tire, unlock chock and move it closer to the tire.
- Remove all twists or knots from the harness or strap
- Place the harness or strap over the tire. Make certain that the harness laps over the top of the tire and is not contacting any part of the vehicle. Chock straps should pull in direct vertical alignment with the centerline of the tire.
- Remove all slack or excess harness.
- Use a  $\frac{1}{2}$ " drive ratchet to tighten the ratchet on the chock until the harness is tight.
- DO NOT over tighten the strap assembly. The tire must not be compressed over  $\frac{1}{2}$  of an inch (24 FT-LBX)
- Inspect chock-locking pins to ensure that they are fully engaged.
- Unused chocks and harnesses are to be properly stored.

*Any modification to these procedures must be in writing and have both the carriers' and SOA's approval.*

### ▼ **Holden Grate Lock Chock**

A minimum of four chocks are used for each vehicle, one at each of the four tires. No tools are needed.

Chocks are to be placed on the outboard side of each of the vehicle's four tires.



### **Double chock vehicles located in A1, A5, B1 and B5 positions.**

The lateral restraint paddle is always to be placed to the inside tire wall. The chocks are color coded to indicate which side the lateral restraint paddle is located: Red is the right side and Lime is the left side.

Remove the chock from the storage pan located at the bottom of the side panel. The chock is released from the storage pan by rotating the handle upwards until it is horizontal with the multi-level deck.

Place the chock on the deck and adjust the height to the highest possible setting that will provide at least 2" of clearance between the top of the chock and any portion of the vehicle. To adjust the height, push down the top of the hinge assembly and pull the faceplate outward and upward.

Place the chock in the floor grating as tightly as possible against the tire, both laterally and longitudinally. Make sure that the locking handle is vertical, the chock is fully seated, the paddle is to the inside of the tire and that there is no more than  $\frac{3}{4}$ " space between the paddle and tire or between the chock face plate and tire. Re-position the chock until all of these conditions are met.

Rotate the locking handle forward to the full lock position. Check to make sure the chock is fully seated and locked in the grating.

Repeat procedure at all four tires.

Unused chocks are to be placed in their lowest height setting and properly stored in their storage pans.

*Any modification to these procedures must be in writing and have both the carriers' and SOA's approval.*



### ▼ Chain (*NOT to be used with Subaru vehicles*)

Four chains are to be used at all times.

Never use towing brackets for tie-down (see Tie-Down Procedures for specific models.)

Equal tension is to be applied to all chains attached to each vehicle. To achieve this, take up all slack in the chain and then tighten the ratchet one/two notches. Make sure no part of the chain assembly touches the vehicle.

After tensioning tie-down chains, the following must be checked:

- All four chains must be taut.
- Chain angles must be as specified for each model.

Front and rear chains must exert opposing forces.

Tie-down chains must allow a minimum of 2" clearance with vehicle splash panel, bumpers, suspension, or exhaust components.

Tools specifically designed for use with each type of tie-down device are to be utilized during the tie-down procedure.

Unused tie-down devices are to be locked in the tie-down track and their chains are to be stored in the track.

*Any modification to these procedures must be in writing and have both the carriers' and SOA's approval.*

### ■ Unloading

When off loading multi-level rail cars, they are to be spotted so that different deck heights are not mixed and in such a manner that vehicles can be driven off forward.

Extreme caution is to be used when opening and closing end doors on railcars. SealSafe end doors continue to experience failure in the pivot bolt area. When there is a total failure of the pivot bolt, the top of the door is not secured and may tilt outward until the green safety cable engages the door to prevent it from falling. However, the green safety cable may also fail allowing the door to fall to the ground. Before attempting to move doors, make a visual inspection to help insure the door is safe to operate.

Chocks and harnesses are to be removed from the vehicle and properly stored in the storage boxes or hung on the side panels of the multi-level.

To remove the **Thrall Wedge Chock**, disengage the ratchet release handle while pulling on the end of the harness strap. Ratchet must be completely unwound.

To remove the harness from the tire, move it toward the keyhole plate to provide enough slack to unhook the plate from the stud on the chock, then slide the harness off the tire.

To remove the chocks, push the locking pin handle toward the vehicle and then lift it up in the slot on the chock. This locks the pin in the open position so that the chock can be moved.

Due to vehicle movement during transit, a pry bar may have to be used to move the locking pin. So if needed, right above the locking pin handle, is a built-in pry point.

Carefully remove the chocks, one at a time, and place them end to end in their storage box, making sure they are completely down into the box.

Using the keyhole plate, hang the harness on the bolt that is attached to the side shielding. The harness of two chocks should be extended and crossed as stenciled on the multi-level's interior.

To remove the **Holden Grate Lock Wheel Chock**, rotate the locking handle away from the tire as far as possible. When the handle goes to the full unlock position the chock will slightly lift from the track.

If the chock does not release with hand pressure, downward foot pressure on the handle may be used.

If the vehicle is resting very tightly against the chock it may be necessary to move the vehicle away from the chock slightly.

Carefully remove the chock and place it on the multi-level deck, collapse the chock to the lowest possible setting, place it in the matching color coded storage pan, and lock in position by rotating the locking handle to the full lock position.

When removing **chains**, tie-down hooks are to be removed from vehicles. Tie-down chains are to be placed between the tie-down tracks.

Make certain chains are completely removed from all vehicles and are set clear of the wheel path.

Always use the correct wrenches when removing securement devices.

Avoid vehicle contact at all times.

## **Procedure for Handling Damaged Subaru Vehicles at Rail Destinations**

- **Minor Damage** (small scratch or dent): **Ship vehicle.** Email a copy of the DIU Report to Subaru Logistics Department (see below).
- **Major Damage/Inoperable Unit.** **Do Not Ship vehicle.** Notify Fenkell Automotive Services immediately of the VIN, area, type and severity of the damage by entry into Vehi-trac. Email a copy of the DIU Report to Subaru Logistics Department (see below). Vehicle cannot ship until authorization has been received from Subaru of America (SOA) or Fenkell.

**E-mail:**      [mole@subaru.com](mailto:mole@subaru.com)  
                  [bbau@subaru.com](mailto:bbau@subaru.com)  
                  [vehicle\\_claims@subaru.com](mailto:vehicle_claims@subaru.com)

**Phone:**      856.488.8681      Barbara Baumgartner  
                  856.488.3428      Mike Olearchik

- SOA will provide written authorization for shipping instructions or arrange for a more detailed damage evaluation.

## **Appendix A: Subaru of America Key Styles by Model**

### **All 2018 Models – Push-Button Start**

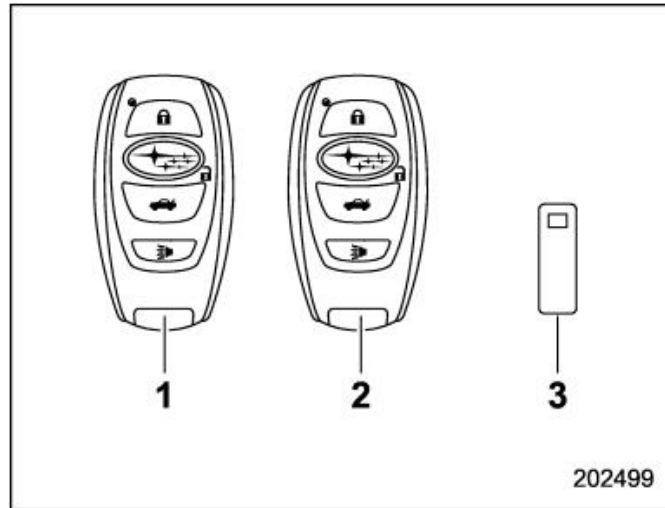

- 1) Access key (main)
- 2) Access key (sub)
- 3) Key number plate

### **All 2018 Models – Turn Key Start**

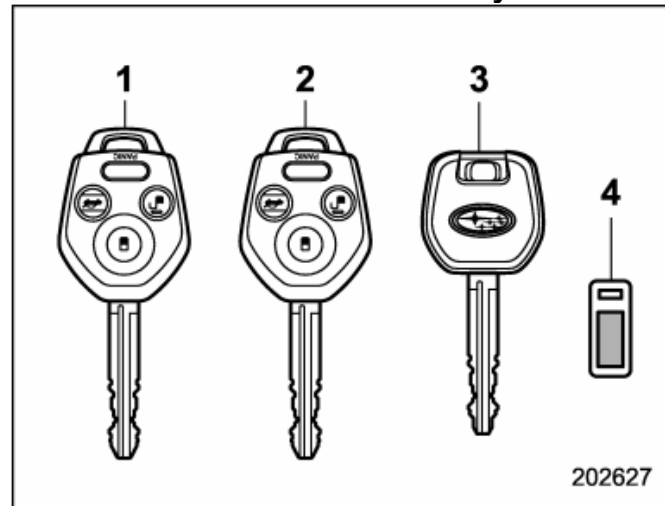

- 1) Master key
- 2) Submaster key
- 3) Valet key
- 4) Key number plate

## **Appendix B: 2021 Vehicle Weights/Dimensions**

### SUBARU - 2021 Domestic Models

#### WEIGHTS AND DIMENSIONS

Model	Legacy					
	L	H	W	WB	GC	Curb Wt.
Base	190.6	59.1	81.8**	108.3	5.9	3500
Premium	190.6	59.1	82.0***	108.3	5.9	3504
Sport	190.6	59.1	82.0***	108.3	5.9	3524
Limited	190.6	59.1	82.0***	108.3	5.9	3581
Limited XT	190.6	59.1	82.0***	108.3	5.9	3779
Touring XT	190.6	59.1	82.0***	108.3	5.9	3790

Model	Outback					
	L	H	W	WB	GC	Curb Wt.
Base	191.3	66.4*	81.8**	108.1	8.7	3635
Premium	191.3	66.4*	82.0***	108.1	8.7	3655
Limited	191.3	66.4*	82.0***	108.1	8.7	3730
Touring	191.3	66.4*	82.0***	108.1	8.7	3772
Onyx Edition XT	191.3	66.4*	82.0***	108.1	8.7	3885
Limited XT	191.3	66.4*	82.0***	108.1	8.7	3926
Touring XT	191.3	66.4*	82.0***	108.1	8.7	3937

Model	Ascent					
	L	H	W	WB	GC	Curb Wt.
Base	196.8	71.6*	85.7**	113.8	8.7	4430
Premium	196.8	71.6*	85.7**	113.8	8.7	4449
Limited	196.8	71.6*	86.1***	113.8	8.7	4499
Touring	196.8	71.6*	86.1***	113.8	8.7	4603

\* Including Roof Rails and Cross Bars in Position

\*\* Including Mirrors

\*\*\* Including Mirrors with Integrated Turn Signals

## SUBARU - 2021 Import Models

### WEIGHTS AND DIMENSIONS

Model	Forester					
	L	H	W	WB	GC	Curb Wt.
Base	182.1	67.5	80.9**	105.1	8.7	3453
Premium	182.1	68.1*	80.9**	105.1	8.7	3525
Sport	182.1	68.1*	81.3***	105.1	8.7	3537
Limited	182.1	68.1*	81.3***	105.1	8.7	3541
Touring	182.1	68.1*	81.3***	105.1	8.7	3589

Model	Impreza					
	L	H	W	WB	GC	Curb Wt.
4 Door Sedan Base (MT)	182.7	57.3	79.4**	105.1	5.1	2976
4 Door Sedan Base	182.7	57.3	79.4**	105.1	5.1	3047
4 Door Sedan Premium	182.7	57.3	79.4**	105.1	5.1	3084
4 Door Sedan Sport	182.7	57.3	79.9***	105.1	5.1	3142
4 Door Sedan Limited	182.7	57.3	79.9***	105.1	5.1	3131
5 Door Base (MT)	176.2	57.3	79.4**	105.1	5.1	2989
5 Door Base	176.2	57.3	79.4**	105.1	5.1	3058
5 Door Premium	176.2	58.9*	79.4**	105.1	5.1	3104
5 Door Sport (MT)	176.2	57.3	79.9***	105.1	5.1	3084
5 Door Sport	176.2	57.3	79.9***	105.1	5.1	3146
5 Door Limited	176.2	58.9*	79.9***	105.1	5.1	3150

Model	WRX / WRX STI					
	L	H	W	WB	GC	Curb Wt.
Base (MT)	180.9	58.1	78.9**	104.3	4.9	3294
Premium (MT)	180.9	58.1	78.9**	104.3	4.9	3351
Premium	180.9	58.1	78.9**	104.3	4.9	3492
Limited (MT)	180.9	58.1	78.9**	104.3	4.9	3371
Limited	180.9	58.1	79.5***	104.3	4.9	3512
STI Base (MT)	180.9	58.1	79.5***	104.3	4.9	3450
STI Limited (MT)	180.9	58.1	79.5***	104.3	4.9	3514

\* Including Roof Rails

\*\* Including mirrors

\*\*\* Including mirrors with Integrated turn signals



**SUBARU - 2021 Import Models**  
WEIGHTS AND DIMENSIONS

<b>Model</b>		<b>BRZ</b>				<b>Curb Wt.</b>
		<b>H</b>	<b>W</b>	<b>WB</b>	<b>GC</b>	
<b>Limited (6MT)</b>	166.7	52	77.8**	101.2	4.9	2798
<b>Limited (6AT)</b>	166.7	52	77.8**	101.2	4.9	2840
<b>tS</b>	166.7	52	77.8**	101.2	4.9	2833

<b>Model</b>	<b>L</b>	<b>H</b>	<b>W</b>	<b>WB</b>	<b>GC</b>	<b>Curb Wt.</b>
<b>Base (MT)</b>	176.5	63.6*	79.0**	104.9	8.7	3117
<b>Base</b>	176.5	63.6*	79.0**	104.9	8.7	3188
<b>Premium (MT)</b>	176.5	63.6*	79.0**	104.9	8.7	3146
<b>Premium</b>	176.5	63.6*	79.0**	104.9	8.7	3223
<b>Sport</b>	176.5	63.6*	79.5***	104.9	8.7	3265
<b>Limited</b>	176.5	63.6*	79.5***	104.9	8.7	3298
<b>Hybrid</b>	176.5	62.8*	79.5***	104.9	8.7	3717

\* Including Roof Rails

\*\* Including mirrors

\*\*\* Including mirrors with Integrated turn signals



## **Appendix C: Delivery Inspection Expectations**

The following guidelines are the expectations that Subaru retailers are required to conform to, regarding vehicle delivery inspections. As soon as the vehicles are off-loaded, the retailer is expected to inspect each vehicle in the presence of the driver.

Documenting any delivery damage or missing items on the (electronic or paper) delivery receipt using the standard transportation damage codes.

Retailers are not allowed to refuse damaged vehicles.

### **■ Vehicle Inspection**

The retailer is responsible for thoroughly inspecting the condition of each vehicle for any damage and/or missing items and to describe these conditions on the delivery receipt at the time of delivery. Digital photos are required.

Carrier regulations allow 1 hour of time for retailer inspection. The time begins when the final vehicle has been unloaded. It is suggested that the inspection begin as soon as the first vehicle has been off-loaded since carriers may charge for time delays beyond 1 hour and these costs may be charged to the retailer.

**WARNING**, a signed delivery receipt, without any exceptions noted, releases the carrier from any damage liability, except for hidden damage (undercarriage).

### **■ Delayed Inspection**

Delayed inspections are only valid when one of the following conditions apply:

#### **▼ Adverse Conditions**

Vehicle inspection may be delayed when vehicles are delivered covered with snow, ice or other contaminants or if weather conditions are such that a full exterior inspection is not possible.

Under these conditions, write, "Subject to Inspection (STI)" on the delivery receipt. Include a brief explanation as to why a delayed inspection was necessary. "For example, "Covered in snow".

#### **▼ "After Hours" or 24/7 STI Delivery**

"After hours" or 24/7 delivery can only occur with **authorized** retailers (in order to be an authorized dealer please contact your Regional Distribution team). However, if vehicles are received when the retailer is closed, inspect the vehicles during the next business day.

**NOTE:** If any retailer personnel sign for vehicles received after posted business hours or accepted delivery hours, then the delivery receipt must indicate "after hours delivery - Subject to Inspection" (STI) and must include the date and time of delivery.

If damage is found, pictures should be taken of damage, including factory installed plastic wrap and then written notification must be sent to the carrier within **2 business days** from the time of vehicle delivery.



## **Appendix D: Crosstrek Hybrid Handling**

### ■ Hybrid Items of note for Vehicle Inspection

The Crosstrek Hybrid comes with a flat tire repair kit, a sun visor, an air pump and a re-charging cable, that should be confirmed when marine and carrier surveys are performed, prior to taking ownership of vehicle.

▼ **Flat Tire Repair Kit and Sun Visor Locations** - Flat Tire Repair Kit is located in rear cargo area under the cargo storage compartment. The Sun Visor is located next to Repair Kit.

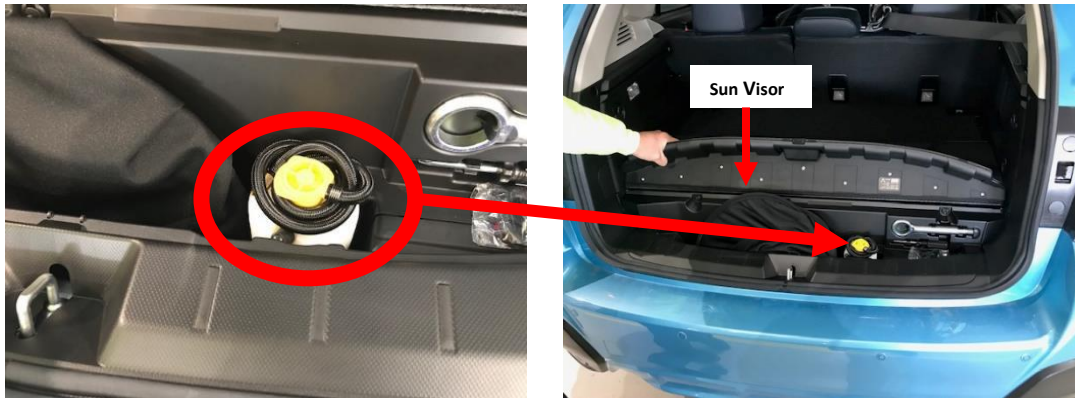

▼ **Air Pump for Tires Location** – The air pump for the tires is housed on the right side of rear cargo panel.



▼ **Electric Re-Charging Cable Location** – The electric re-charging cable is stored behind rear left seat floor during transportation.



## ■ Service Points for Crosstrek Hybrid

### ▼ Hybrid Handling Safety Notes:

• ① **WARNING:** The high voltage system, including the charging system, may remain powered for up to 10 minutes after the vehicle is shut off, disabled, or charging stops. To prevent serious injury or death from severe burns or electric shock, avoid touching, cutting, or breaching any orange high voltage power cable or high voltage component.

• Do not touch any exposed internal components or damaged areas of high voltage electrical components or wire harnesses. If it is necessary to touch high voltage electrical components or wire harnesses, always use insulated tools and safety equipment, and cover damaged areas with insulation tape.

▼ **Tire Replacement** - If a tire needs to be replaced refer to the DOT numbers as the regular Crosstrek will visually look the same but the Hybrid is slightly different in size and make up. U200 prefix for PHEV, Country of Origin is Japan (regular Crosstreks are in Thailand).

▼ **Jump Starting Hybrid Crosstrek** - The battery (12 V) may be jump started if the vehicle does not start and the combination meter is dim or off after depressing the brake pedal and pushing the push-button ignition switch.

The battery (12 V) is located in the driver side of the engine compartment.

When hybrid battery goes dead, charging **MUST** be done with a charging station and not a generator – must be clean power

## Service Points



### Jump Starting Vehicle

1. Make sure the booster battery is 12 volts and the negative terminal is grounded
2. If the booster battery is in another vehicle, do not let the two vehicles touch
3. Turn off all unnecessary lights and accessories
4. Connect the jumper cables exactly in the sequence illustrated
5. Connect one jumper cable to the positive(+)terminal on the discharged 12 V battery
6. Connect the other end of the jumper cable to the positive (+) terminal of the booster battery
7. Connect one end of the other cable to the negative (-) terminal of the booster battery
8. Connect the other end of the cable to the strut mounting nut of the vehicle with the discharged 12 V battery. Make sure that the cables are not near any moving parts and that the cable clamps are not in contact with any other metal
9. Start the engine of the vehicle with the booster battery and run it at moderate speed. Then start the hybrid system of the vehicle that has the discharged 12 V battery
10. When finished, carefully disconnect the cables in exactly the reverse order

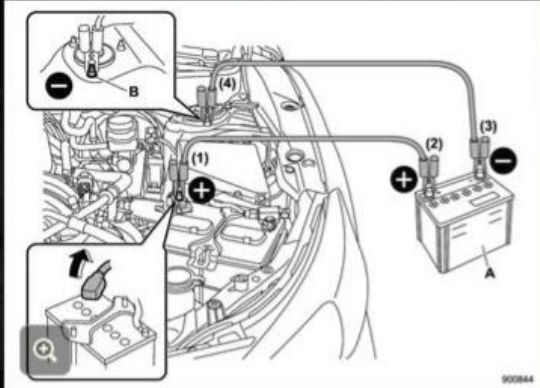

▼ **Towing of Crosstrek Hybrid vehicles** – Use a flat-bed truck is the best way to transport the vehicle. Use the following procedures to ensure safe transportation.

1. Shift the select lever into the Park position.
2. Apply the parking brake.
3. Secure the vehicle onto the carrier properly with safety chains. Each safety chain should be equally tightened, and care must be taken not to pull the chains so tightly that the suspension bottoms out.

Note: If the vehicle has a bumper under guard be careful not to scrape them when placing the vehicle on the carrier and when removing the vehicle from the carrier.